



Measure hard-to-reach, sensitive, or moving target temperatures.

Two instruments in one! Plug in optional K-type surface probe to convert non



6.5" x 3.5" x 1.5"  
380/381/381F/383



6.5" x 3.5" x 1.5"  
384



7.875" x 1.75" x 1.75"  
372/373

**FEATURES**

- Easy to use one button operation
- 0.1 resolution for best reading
- Data hold function
- Soft holster pouch included
- 8:1 distance to spot ratio
- **381F: 6:1 distance to spot ratio**
- Large, easy to read LCD
- °C and °F selectable
- 9V battery included

**SPECIFICATIONS**

FUNCTION	372	373	380	381	381F	383	384
Temp Ranges	-58° to 550°F -50° to 28°C	14° to 950°F -10° to 510°F	-4° to 572°F -20° to 300°C	-4° to 572°F -20° to 300°C	-31° to 572°F -35° to 300°C	-31° to 999°F -35° to 560°C	-31° to 1832°F -35° to 1,000°C
Laser Signaling	Yes	Yes	No	Yes	Yes	Yes	Yes
Accuracy @ 25°C and 0.95 Emmissivity	±(2% of reading, ±3.5°F); whichever is greater	±(2% of reading, ±3.5°F); whichever is greater	±(2% of reading, ±3.5°F); whichever is greater	±(2% of reading, ±3.5°F); whichever is greater	32°F - 158°F: ±2°F <32°F or >158°F: ±(2% of reading, ±3.5°F);whichever is greater	±(2% of reading, ±3.5°F); whichever is greater	-4°F - 32°F: ±5°F 32°F - 1040°F: ±3.5°F 1040°F - 1832°F: ±(2% + 3 digits)
Response Time	500 milliseconds	500 milliseconds	500 milliseconds	500 milliseconds	500 milliseconds	500 milliseconds	500 milliseconds
Emmissivity	0.95 fixed	0.95 fixed	0.95 fixed	0.95 fixed	0.95 fixed	0.95 fixed	0.95 fixed
Spectral Response	7-14um	7-14um	7-14um	7-14um	7-14um	7-14um	8-14um
Operating Temp.	32° to 120°F 0° to 50°C	32° to 120°F 0° to 50°C	32° to 120°F 0° to 50°C	32° to 120°F 0° to 50°C	32° to 120°F 0° to 50°C	32° to 120°F 0° to 50°C	32° to 120°F 0° to 50°C
Battery Type	9V alkaline	9V alkaline	9V alkaline	9V alkaline	9V alkaline	9V alkaline	9V alkaline

**IR FAQ**

**What does "distance to spot ratio" mean?**  
The laser spot needs to be showing inside the target area. An 8:1 "distance to spot ratio" means you are measuring a 1" diameter area at a distance of 8".

**How far can I measure?**  
Distance is unlimited. The size of the target area sets the limit on distance for accurate measurements. Example: If the area you wish to measure is 1 foot in diameter, then you will need to be within 8 feet to record an accurate temperature.

**What is the smallest target I can read?**  
Approximately one-half inch in diameter.

**How do I turn the laser on and off?**  
While holding the Power On button down you can toggle the Lock On button for either laser on or laser off operation. When the laser is activated the laser displays this icon

**What is emissivity?**  
This is a ratio of an object's infrared emission compared to a theoretical black body, considered 1. Emissivity is always less than 1. Adjustable emissivity allows your non-contact thermometer to be adjusted to the surface you are checking to make readings more accurate.

**How do I adjust the emissivity of my contact/noncontact 375, 376, 377?**  
The 375, 376, and 377 feature adjustable emissivity and contact probe capability. This is very useful for determining the emissivity of any surface condition. Simply use the contact probe and record surface temperature. Next use the IR gun and adjust the emissivity until the temperature matches the reading of the contact probes. Copper pipe produces different emissivity properties, ranging from 0.02 to 0.78, due to oxygen oxidation and curvature. You will now have the most accurate reading in the IR mode for that surface.

**How can I make measurements more accurate if I don't have my contact probe or have a fixed emissivity thermometer?**  
Painting the surface being measured matte black will make temperature readings more accurate. A piece of black tape can also be used.

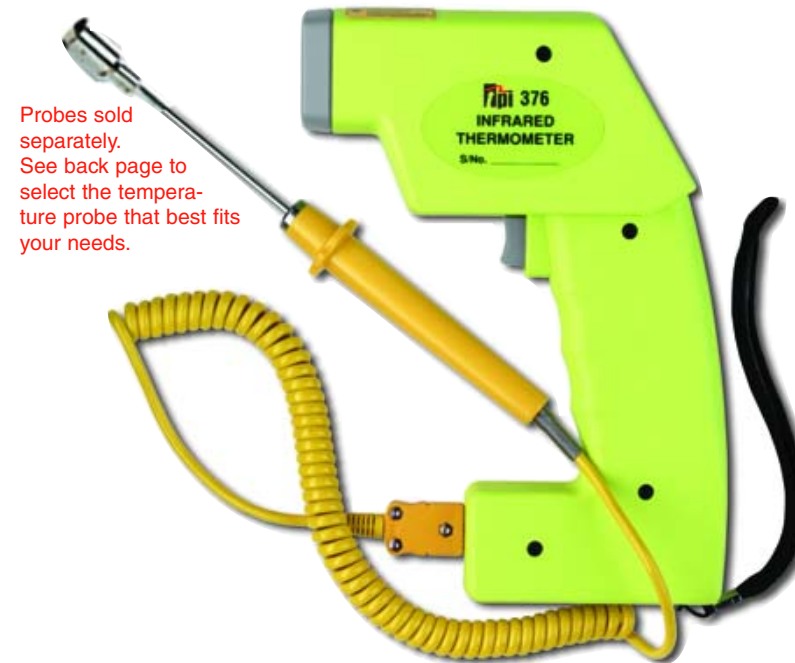

Probes sold separately. See back page to select the temperature probe that best fits your needs.

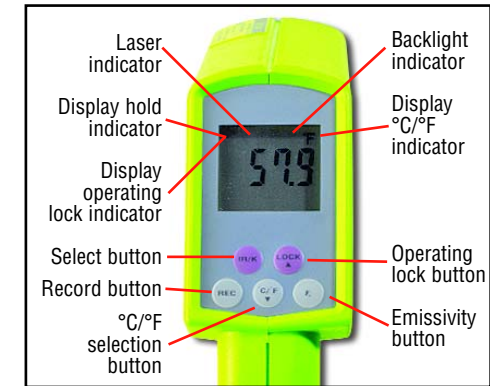

**APPLICATIONS**

- Electrical**
  - Cables
  - Circuit breakers
  - Connections
  - Machinery
  - Motors
  - Transformers
- Food**
  - Grill & surface temperatures
  - Holding cabinets
  - Serving temperatures
  - Storage temperatures
- HVACR**
  - Compressor heads
  - Vents
  - Hot and cold areas in insulation
  - Leaks around cooler or freezer doors
  - Leaks around windows
  - Steam traps
  - Registers



**FEATURES**

- Laser pointer
- Record function (Min/Max)
- Display data hold function
- Back light
- Trigger switch
- 8:1 distance to spot ratio
- °C and °F selectable
- Gun-type compact design
- Operating lock function
- 9V battery and soft pouch included

**SPECIFICATIONS**

FUNCTION	375	376	377
Temp. Ranges	0° to 950°F -18° to 510°C	-58° to 950°F -50° to 510°C	0° to 1832°F 18° to 1000°C
Accuracy @ +23°C CE=0.95	30° to 950°F -1° to 510°C ±2% of reading or ±3.5°F (2°C) whichever is greater	30° to 950°F -1° to 510°C ±2% of reading or ±3.5°F (2°C) whichever is greater	30° to 950°F -18° to 1000°C ±2% of reading or ±3.5°F (2°C) whichever is greater
Response Time	500 milliseconds		
Spectral Response	7 - 14um		
Emmissivity	0.3 to 0.99 adjustable		
Display Resolution	0.1°F and 0.1°C or 1°F and 1°C		
Ambient Operating Range	32° to 120°F and 0° to 50°C		
<b>PROBES</b>			
K-type Range	-40° to 2192°F and -40° to 1200°C		
K-type Accuracy	±(0.5% of reading +3°F)		

**TEMPERATURE PROBES**

- Choose from a complete line of probes for your unique job.
- Contact or surface
  - Gas, air, flame
  - High temp. immersion
  - Semi-frozen product

**Distance to Laser Point Diameter Ratio**

Distance to Spot Ratio = 8:1  
Example Target Size = 1" x 1"

- BEST**  
Laser spot size is 1/2" at a distance of 4"
- MARGINAL**  
Laser spot size is 1" at a distance of 8"
- UNACCEPTABLE**  
Laser spot size is 1 1/2" at a distance of 1"

**CAUTION LASER RADIATION**

Do not stare at laser beam or point toward others.  
Keep these products out of reach of children.  
Output < 1 Mw Wavelength 645 - 660nm



# IR Kit and Temperature Probes

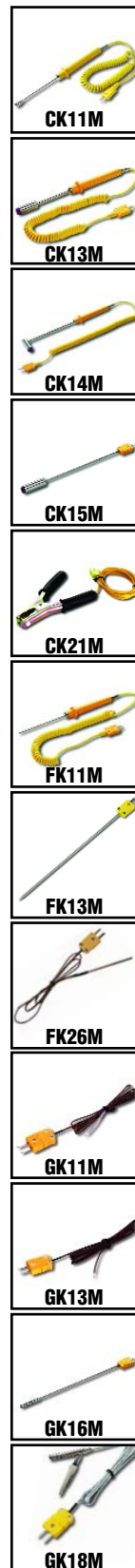

## Thermocouple Temperature Probes for 375/376/377

Model # Description	Range°F/°C	Stem Length	Diameter	Lead Length	Insulation Material
<b>CK11M</b> K-type surface probe with ribbon sensor to contact uneven surfaces	-50° to 250°C -50° to 482°F	100mm 4"	3.2mm 0.126"	1M 3'	PVC
<b>CK13M</b> Heavy duty K-type surface probe with spring sensor to maintain pressure on surface being measured	-50° to 650°C -50° to 1202°F	100mm 4"	6.4mm 0.25"	1M 3'	PVC
<b>CK14M</b> Heavy duty K-type surface probe with spring sensor to maintain pressure on surface being measured	-50° to 650°C -50° to 1202°F	150/36mm 5.9"/1.4"	6.4mm 0.25"	1M 3'	PVC
<b>CK15M</b> Heavy duty K-type surface probe to use with HK11M handle.	-40° to 510°C -40° to 950°F	203mm 8"	3.75mm 0.148"	NA	NA
<b>PIPE CLAMP PROBE CK21M</b> K-type thermocouple pipe clamp for pipe diameters up to 1.2" (30mm) and for temperatures up to 212°F (100°C)	-50° to 100°C -45° to 212°F	NA	NA	1M 3'	PVC
<b>FK11M</b> K-type general purpose probe.	-50° to 250°C -50° to 482°F	100mm 4"	3.2mm 0.126"	1M 3'	PVC
<b>FK13M</b> K-type general purpose probe to use with HK11M handle	-40° to 850°C -40° to 1,562°F	203mm 8"	3.75mm 0.148"	1M 3'	PVC
<b>FK26M</b> Standard K-type thermocouple probe. For use with Pete's plugs to measure temperature	-40° to 204°C -40° to 400°F	63.5mm 2.5"	3.18mm .125"	.6M 25.5"	Teflon FDA Approved
<b>GK11M</b> Standard K-type thermocouple probe.	-50° to 510°C -50° to 950°F	NA	NA	1.2M 4'	Fiberglass
<b>GK13M</b> Standard K-type thermocouple probe.	-50° to 510°C -50° to 950°F	NA	NA	1.2M 25.5"	Teflon FDA Approved
<b>GK16M</b> K-type air probe for HK11M handle. Shielded tip with perforations to protect sensing area.	-40° to 260°C -40° to 500°F	203mm 8"	3.75mm 0.148"	NA	NA
<b>GK18M</b> Shielded tip with perforations to protect sensing area.	-40° to 510°C -40° to 950°F	NA	NA	1M 3'	Stainless Steel

## 375C1 • 376C1 • 377C1

### Save Over 20% with a Non-Contact / Contact Kit

Get a Non-Contact/Contact Thermometer and all the essential probes in one convenient, money-saving kit!



## 375C1 • 376C1 • 377C1

Each kit includes your choice of the 375, 376, or 377; along with a soft A755 case with shoulder straps; and the following probe attachments: CK15M, Fk13M, GK13M, GK16M, HK11M. For details on the 375, 376, and 377 see the inside of this product brochure.

## Probe Handle HK11M

**HK11M**  
• Heavy-duty handle for K-type thermocouple probes.  
• Can be used with the CK15M, FK13M, and GK16M.  
• 3' coiled lead for durability and long reach.



# Your Tools at Work

## Infrared, Non-Contact Temperature Testers

### Infrared Applications

#### Food Safety

- Grill and surface temperatures
- Holding cabinets
- Serving temperatures
- Storage temperatures
- Food transport

#### HVACR

- Compressor heads
- Vents and registers
- Hot and cold areas in insulation
- Leaks around cooler or heater doors
- Floor heat
- Steam traps

#### Plant/Facility

- Preventive and predictive maintenance
- Electrical/circuit connections
- Motor, pumps, and bearing

#### Electrical

- Cables
- Circuit breakers
- Connections
- Motors
- Machinery
- Transformers

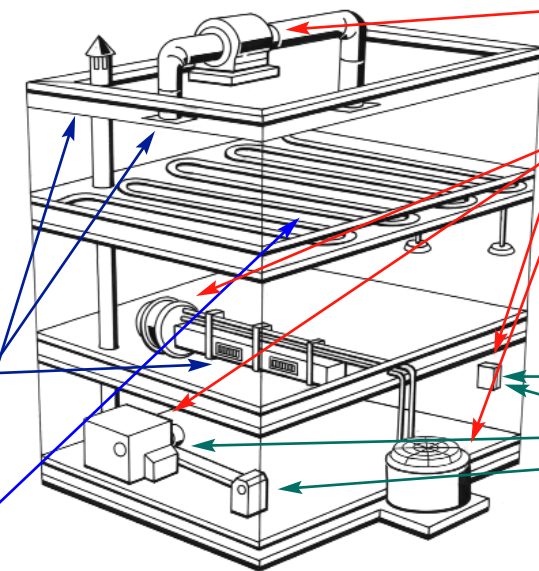

## Increase Productivity and System Performance

Thoroughly testing and diagnosing high efficiency HVACR systems or large surface areas can be labor intensive and expensive. Using the appropriate non-contact thermometer can reduce man hours and help insure system performance more easily, accurately, and affordably.

- Monitor several feet of ductwork, insulation, or other large areas in less time.
- No need to drill holes to insert temperature probes.
- Safe and contamination free!
- Measure temperatures from ground level - no ladders.

### The Value Leader™

## • New • New • New • New • New • New • New • New • New • New • New • New • New • New • New • New •

## Close-Focus, Pocket-Size Infrared Thermometer



1.5" W x 2.75" H



- **Close Focus** 1/8" ~ 1.5"
- **Selectable Fahrenheit or Centigrade** temperature range: -7° to 248°F or -22° to 120°C
- **Compact:** Easily fits in your pocket
- **Auto Data Hold:** Point the unit at the surface to be measured then press and hold the ON/SET button. Temperature will be displayed in less than 2 seconds and held on the display for 10 seconds

- **Min/Max** function displays the minimum or maximum temperature of 8 samplings in 0.5 seconds
- **AUTO** sets the 368 into scan mode to continuously scan surface temperatures in real time. In this mode unit automatically powers off after 60 minutes.
- **NOTE:** Close focus IR thermometers should be held a distance .5 to 2 inches from surface to obtain an accurate reading

### SPECIFICATIONS

Range	-7° to 248°F or -22° to 120°C
Operating Temp.	-32° to 104°F or 0° to 40°C
Accuracy	2% or reading or ±2°C, whichever is greater
Response Time	Less than 0.5 second
Resolution	0.1°F/°C
Emmissivity	0.95 fixed
Distant to spot ratio	1:1.3
Battery	A003
Battery Life	50 hours continuous use, auto after 10 sec.